

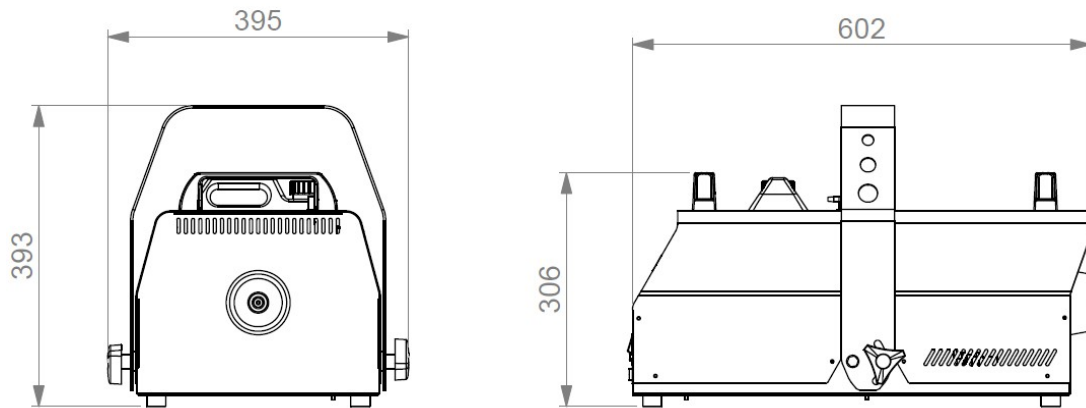

user manual

ZV ZR45 SmokeMaker™



© 2017 American Safety & Health Promotions LTD and Martin Professional™ ApS. Information subject to change without notice. American Safety & Health Promotions LTD and all affiliated companies disclaim liability for any injury, damage, direct or indirect loss, consequential or economic loss or any other loss occasioned by the use of, inability to use or reliance on the information contained in this manual.

American Safety & Health Promotions LTD 513 Stewart St. Suite G Charlottesville Virginia 22902 | 888-289-2747

Contents

Dimensions/Legal	2
Contents	3
Safety information	4
Product overview	7
Product description	7
Features at a glance	7
Product details	8
Quick Start	9
Setting up	9
Making fog	9
Installation and Setting Up	10
Location	10
AC power	10
Setting up	11
Final checks	11
Turning on the power	11
Control Settings	12
Overview	12
Setting Run modes	12
Setting Fog output density	12
Setting the Timer	13
Using the Settings menu	13
Setting the DMX base address	13
Display back light setting	13
Setting the master-slave link mode	13
Priming the machine after fluid out	14
Resetting options to factory settings	14
DMX Control	16
Overview	16
Connection	16
DMX functions	16
Optional PLC Interface Control	17
Overview	17
Approved Fog Fluid Types	18
ZR45 Temperature Menu	19
Pro Clean Supreme Fluid	20
Basic Service	21
Cleaning	21
Fuse replacement	21
Troubleshooting	22
Status Messages	23
Resetting the machine after fluid out	23
Technical Specifications	24

Safety information



Read the safety precautions in this manual before installing, operating or servicing this product.

The following symbols are used to identify important safety information:



Caution
Safety
hazard. Risk
of severe
injury or
death.



Caution!
Burn
hazard. Hot
surface. Do
not touch.



Danger!
Hazardous
voltage.
Contact will
cause electric
shock.



Caution
Fire
hazard.



Warning! This product is not for household use. It presents risks of injury due to electric shock, burns, falls and respiratory problems!

Read this manual before operating the machine, follow the safety precautions listed below, and observe all warnings in this manual and printed on the machine. Use the machine only as described in this manual and in accordance with local laws and regulations.

If you have questions about how to operate the machine safely, or if you have followed the instructions in this manual and the machine is malfunctioning, please contact American Safety & SmokeMaker™ Service.

Preventing electric shocks



- Always ground (earth) the machine electrically.
- Use only a source of AC power that complies with local building and electrical codes, and that has both overload and ground-fault protection.
- Before connecting the machine to power, check that the voltage indicated on the machine's serial label matches your local AC power voltage. If your AC power voltage does not match, do not use the machine. Contact American Safety & SmokeMaker Service for assistance.
- Before using the machine, check that all power distribution equipment and cables are in perfect condition and rated for the current requirements of all connected devices.
- If the machine or any cables connected to it are in any way damaged, defective, wet, or show signs of overheating, stop using the machine and contact American Safety & SmokeMaker Service for assistance. If the supply cord is damaged, it must be replaced by a special cord or assembly available from the manufacturer or its service agent.
- Disconnect the machine from AC power before servicing and when not in use.

- This machine is not waterproof and should not be exposed to wet outdoor conditions. Do not immerse in water or any other liquid. Do not expose to high-pressure water jets.
- Do not spill fluid over or inside the machine. If fluid is spilled, disconnect AC power and clean with a damp cloth. If fluid is spilled onto electronic parts, take the machine out of service and contact American Safety & SmokeMaker for advice.
- Do not remove the covers or attempt to repair a faulty machine. Refer any service not described in this manual to American Safety & SmokeMaker.
- Do not operate the machine if any parts are damaged, defective or missing.
- Moisture and electricity do not mix. Do not aim fog output at electrical connections or devices.

Preventing burns and fire



- The fog produced by the machine is hot enough to cause burns when it leaves the nozzle, and very hot droplets of fluid escape occasionally. Keep people and objects at least 600 mm (24 in.) away from the fog output nozzle.
- Do not touch the fog output nozzle during or after use – it becomes extremely hot and remains hot for several hours after the machine has been shut down.
- Fog output contains glycol, a flammable alcohol that burns with an almost invisible blue flame. Do not point fog output at sources of ignition such as open flames or pyrotechnic effects.
- Do not attempt to bypass thermostatic switches, fluid sensors or fuses.
- Replace fuses only with ones of the type and rating specified in this manual for the machine.
- Provide a minimum free space of 100 mm (4 in.) around the machine.
- Provide a minimum free space of 500 mm (20 in.) around fans and air vents and ensure free and unobstructed air flow to and around the machine.
- Keep the machine at least 600 mm (24 in.) away from combustible and heat-sensitive materials.
- Do not operate the machine if the ambient temperature (T_a) is below 5° C (41° F) or above 40° C (104° F).
- Do not operate the machine if the relative air humidity exceeds 80%.

Preventing injuries

- Fasten the machine securely to a fixed surface or structure when in use. The machine is not portable when installed.
- Ensure that any supporting structure and/or hardware used can hold at least 10 times the weight of all the devices they support.
- If suspending from a rigging structure, fasten the machine to a rigging clamp. Do not use safety cables as the primary means of support.
- If the machine is installed in a location where it may cause injury or damage if it falls, install as directed in this manual a secondary attachment such as a safety cable that will hold the machine if a primary attachment fails. The secondary attachment must be approved by an official body such as TÜV as a safety attachment for the weight that it secures, must comply with EN 60598-2-17 Section 17.6.6 and must be

capable of bearing a static suspended load that is ten times the weight of the machine and all installed accessories.

- Check that all external covers and rigging hardware are securely fastened.
- Block access below the work area and work from a stable platform whenever installing, servicing or moving the machine.
- Do not operate the machine with missing or damaged covers or shields.
- In the event of an operating problem, stop using the machine immediately and disconnect it from power. Do not attempt to use a machine that is obviously damaged.
- Do not modify the machine in any way not described in this manual or install other than genuine American Safety & SmokeMaker parts.
- Refer any service operation not described in this manual to a qualified technician.
- Fog output can cause condensation. Do not point the output at smooth floors. Floors and surfaces may become slippery. Check these frequently and wipe dry as necessary to avoid any danger of slipping.
- Ensure at least 2 m (6.6 ft.) visibility in areas where fog is being produced.
- Fog fluid contains food-grade glycols in solution but may present health risks if swallowed. Do not drink it. Store it securely. If eye contact occurs, rinse with water. If fluid is swallowed, give water and obtain medical advice.
- This appliance is not intended for use by persons (including children) with reduced physical sensory or mental capabilities, or lack of experience and knowledge, unless they have been given supervision or instruction concerning use of the appliance by a person responsible for their safety. Children should be supervised to ensure that they do not play with the appliance.

Preventing breathing problems



- A machine can operate safely only with the fog fluid it is designed for. Use the machine only with fluids specified under “Approved fluid types” on page 18 or you may cause the release of toxic gases, presenting a severe health hazard. You will also probably damage the machine.
- Do not create dense fog in confined or poorly ventilated areas.
- Do not expose people with health problems (including allergic and/or respiratory conditions such as asthma) to fog output.
- Do not point fog output directly at a person’s face or at face height.

For the latest user documentation and other information for this and all American Safety & SmokeMaker products, please visit the American Safety & SmokeMaker website at:

<http://www.americansafetyandsmoke.com/>

If you have any questions about how to install, operate or service the fixture safely, please send us a secure message at:

<http://www.americansafetyandsmoke.com/contact-us.html>

or call 1-888-289-2747, or 1-434-977-2700.

Product Overview

Product description

The ZV ZR45 SmokeMaker™ provides a uniquely flexible and convenient solution to a wide range of fog requirements whether permanently installed or taken on the road. Featuring a high efficiency heating block and accepting multiple weights of fluid, the ZV ZR45 SmokeMaker™ product can create anything from an ephemeral steam chase to a dense, long-lasting “whiteout”.

An advanced control panel with LCD screen can be operated on the machine or removed and used as a remote controller, or the machines may be operated by DMX with full RDM capability for remote setup and status monitoring.

ZR45

This manual contains instructions for all machines in the range, but some features are different. These symbols show information which is specific to a particular machine.

Congratulations on your purchase of the ZV ZR45 SmokeMaker™ product from American Safety & SmokeMaker. Details of the full range of our products are available on our website at:

<http://www.americansafetyandsmoke.com/>

Features at a glance

- Robust roadworthy design
- Integrated digital remote control
- DMX with RDM
- Hanging bracket included
- Continuous micro-processor controlled effect output
- Diverse fluid options for different applications
- Soft start technology
- Fluid sensing system
- Easy external fluid hook-up
- Optional PLC Interface and ducting kits



Use only an approved American Safety & SmokeMaker fog fluids as shown on page 18. Use of other fluid will void warranty.

Product Details
ZV ZR45 SmokeMaker™

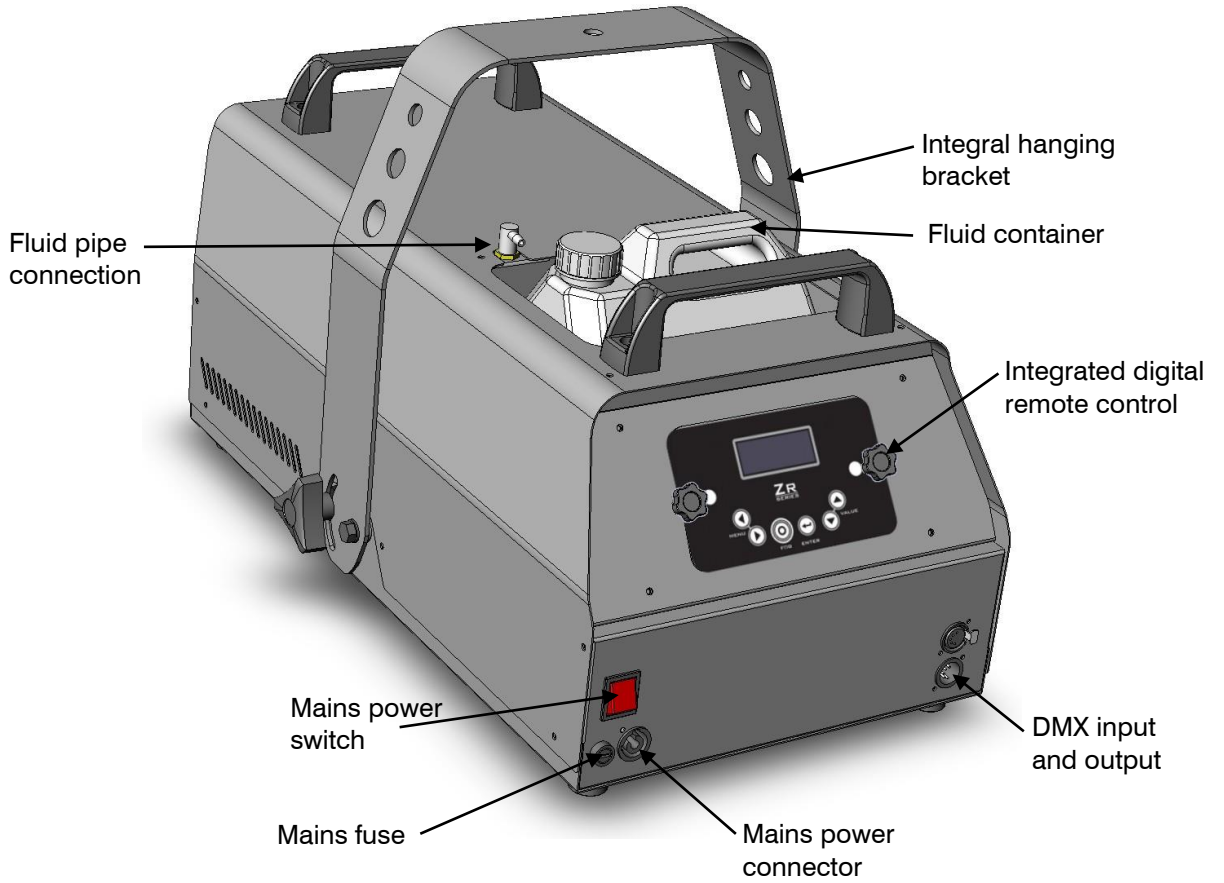

If suspending overhead:
Loop safety cable under
hanging bracket and
secure

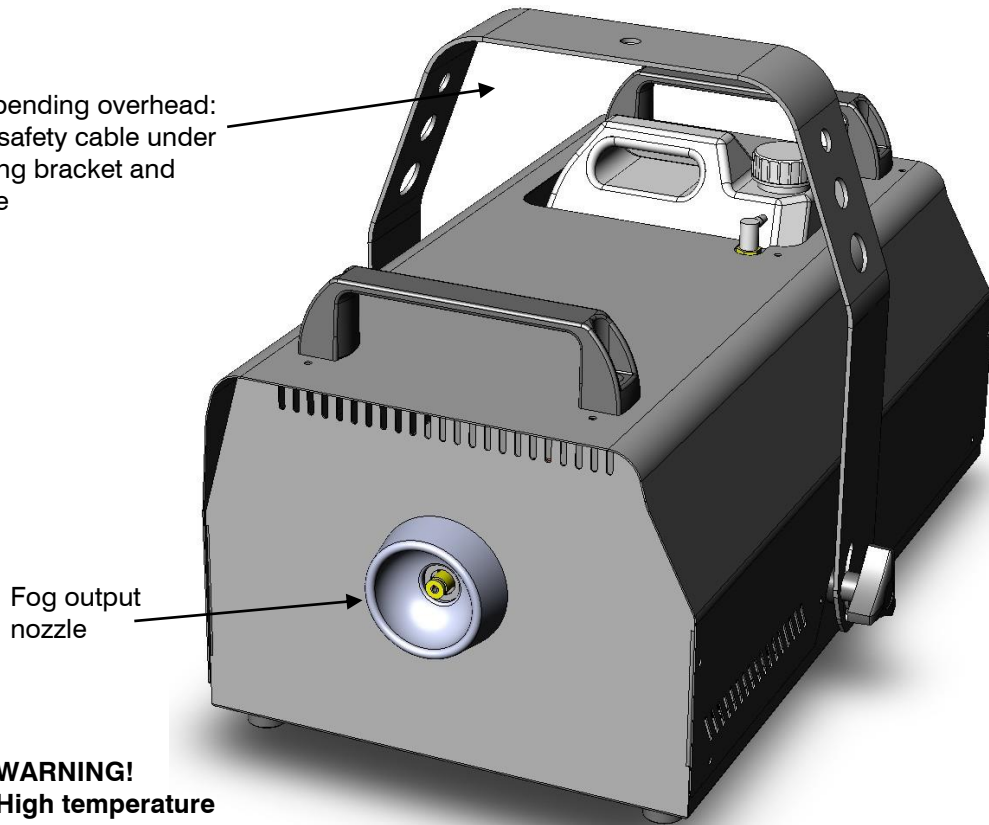

WARNING!
High temperature
vapor and surfaces

Quick Start

You are no doubt eager to switch on the machine and try it out by making a lot of fog. This section tells you how to do that. However, please also make the time to read the safety and servicing instructions in the remainder of this manual.

Setting up

Locate the machine in a suitably large area with nothing in front of the fog output.

Fill the fluid tank with an approved American Safety & SmokeMaker fog fluid as shown on page 18.

Connect the machine to a suitably rated power source. The power requirements are:

1200W 220-240V EU / 1050W 100-130V US

1550W 220-240V EU / 1450W 100-130V US

2100W 220-240V EU / 1800W 100-130V US

Now set the mains switch on the rear of the unit, to the 'ON' (I) position. The display will show **HEAT**. If the display shows **OFF**, press the **FOG** button on the control panel or set the **RUN MODE** to **CONTINUOUS**. After about 6-8 minutes the display should show **FOG LEVEL** (along with the set output level) and the machine will begin producing fog. If the display shows **READY** press the **FOG** button on the control panel.

If you want to adjust the fog density manually, press the Menu < > buttons until the display shows **FOG LEVEL** and use the Value up/down buttons to select a value above 0% then press the Enter button to store this value.



If no fog is produced it may be necessary to prime the machine. Press the Menu <> buttons until the display shows PRIME (located in the SETTINGS submenu), then press the Value Up button so the display shows YES, then press the Enter button.

Installation and Setting Up



DANGER! DO NOT operate the machine until you have read and observed all the precautions listed under “Safety information” on page 4.

Location

The ZV ZR45 SmokeMaker™ machine is designed to be located on the floor or may be suspended using the fitted hanging bracket. The machine can operate in any orientation from 45 degrees upwards to 45 degrees downwards. Steeper tilting may cause fluid leakage.

If the machine is to be suspended, ensure the mounting surface can support the weight of the machine. Do not suspend the machine over areas where people will be underneath. Use only the fitted hanging bracket to suspend the machine.

Ensure that there is at least 100mm (4 in.) clearance all-round the machine and at least 600mm (24 in.) in front of the fog output.



The machine is delivered with white nylon shipping bolts fitted to the hanging bracket in place of the normal hand-wheel bolts. Before first use, remove the shipping bolts and replace them with the hand-wheel bolts (outside of bracket) and spacers (inside of bracket) which are supplied separately in the packaging.

AC power

Before using the machine, ensure that a grounding-type (earthed) power plug that fits the local power outlets is installed on the power cable provided.



DANGER! Make sure the power plug is correctly rated:

- For EU ZV ZR45 SmokeMaker™ use a plug rated at 10 A minimum.
- For US ZV ZR45 SmokeMaker™ use a plug rated at 20 A minimum.

When installing the plug, follow the plug manufacturer’s instructions and connect pins as follows:
Yellow and green wire to ground (earth), blue wire to neutral and brown wire to live.

The table below shows some common pin identification schemes.

wire	function	marking	screw colour
brown	live	“L”	yellow or brass
blue	neutral	“N”	silver
green/yellow	earth		green

Before connecting the machine to power, verify that the AC supply is adequately dimensioned for the current draw of the machine.

1200W 220-240V EU / 1050W 100-130V US

1550W 220-240V EU / 1450W 100-130V US

2100W 220-240V EU / 1800W 100-130V US

Check that the local AC voltage is appropriate, as indicated on the machine's serial number label. If your AC voltage is outside the appropriate range, do not use the machine. Contact American Safety & SmokeMaker Support for assistance.

Setting up

Fill the fluid tank with an approved American Safety & SmokeMaker fog fluid as shown on page 18. If DMX control is being used, connect the machine to the DMX line (see page 16).

If you are using several machines from one control panel in master-slave link mode, link the machines in a daisy-chain using the DMX input and output sockets. It does not matter which socket is used as input or output.

Final checks

Before applying power to the machine, verify the following:

- the machine is safely located or installed and meets the location requirements stated on page 10
- the operator is familiar with, and able to comply with, the requirements for safe operation listed on page 4.
- the fluid is one of the Approved American Safety & SmokeMaker fluids listed under "Approved fluid types" on page 18.
- the machine is electrically grounded (earthed)
- the AC power distribution circuits and lines are adequately rated for the current load

Turning on the power

Set the mains switch on the rear of the unit, to the 'ON' (I) position. The display will show **HEAT**. If the display shows **OFF**, press the **FOG** button on the control panel or set the **RUN MODE** to **CONTINUOUS**. After about 6-8 minutes if no DMX is connected the display should show **FOG LEVEL** (along with the set output level) and the machine will begin producing fog. If DMX is connected the display will show **DMX** when the machine is ready.

The machine will remember its state from when it was turned off last time, so it will only power up in OFF mode if you have previously disabled the heaters.



To obtain maximum output, wait another few minutes after the READY indication is shown, as the machine continues to heat to full operating temperature and fog output is reduced while the unit is heating up.

Control Settings

Overview

The **integrated digital remote control** on the rear of the machine allows you to configure it using option menus.



The integrated digital remote control may be removed from the unit and used as a handheld remote control by removing the two hand wheel bolts either side of the display. The display cable may be extended up to 25 m (82 ft.) using standard 3-pin XLR cable.

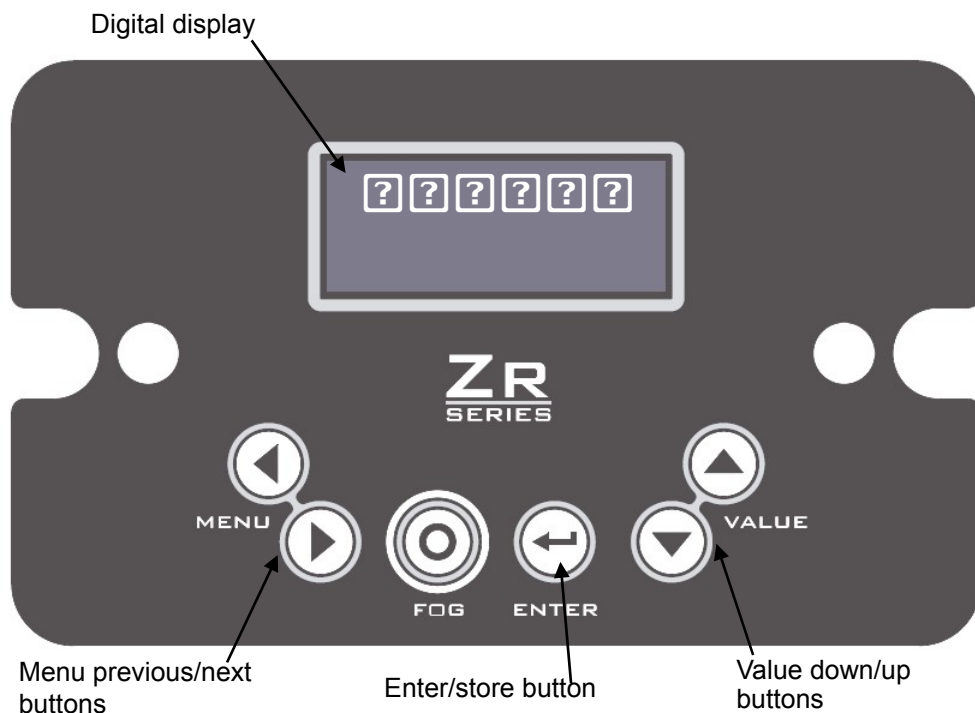

Setting Run modes

The RUN MODE menu sets the operational mode of the machine, and can also be used to shut down the heater. Settings are Off (shutdown, heaters off), Standby (heaters remain on), Timer mode or Continuous mode.

Use the Menu Previous / Next buttons to select the RUN MODE option.
Use the Up/Down buttons to select OFF, STANDBY, TIMER, CONTINUOUS.
Press the Enter button to store the setting. The display shows SET.

Selecting OFF will disable the heaters on the unit.

Setting Fog output density

Use the Menu Previous / Next buttons to select the FOG LEVEL option.
Use the Up/Down buttons to select the density from 0% - 100%
Press the Enter button to store the fog setting. The display shows SET.



If you want to temporarily change the fog density, do not press Enter. The fog setting will go back to its stored value next time the machine is powered up. This applies to all options.

Setting the Timer

Set the RUN TIME and OFF TIME values from the menu. Then select the TIMER option from the RUN MODE menu. The timer values are set in seconds and are in the range 0-99. The Fog value is taken from the FOG LEVEL menu. The timer will cycle continuously until the run menu is changed. Use this mode for maintaining a low level of fog in smaller venues.

Using the Settings menu

Options such as the DMX base address, display brightness, DMX stand-alone linking, priming, factory reset and temperature control (ZR45 only) are found in the SETTINGS menu.

Use the Previous / Next buttons to select the SETTINGS option. Press the Enter button to go to the SETTINGS menu. To return to the main menu, use the Previous / Next buttons to select EXIT and press Enter.

Setting the DMX base address

Use the Previous / Next buttons to select the DMX option from the SETTINGS menu. Use the Up/Down buttons to set the DMX base address from 001 to 511. If you hold down the button the address will count up or down more quickly. Press the Enter button to store the address setting. The machine will automatically respond to a DMX controller whenever it is connected.

When using in a DMX system ensure the LINK MODE menu is set to RECEIVE (the default setting) to avoid causing DMX errors to other devices on the system.

Alternatively, the DMX base address can be set via RDM.

Display back light setting

You can set the brightness of the display backlight using the BACK LIGHT option.

Use the Previous / Next buttons to select the BACK LIGHT option from the SETTINGS menu. Use the Up/Down buttons to change the option to LOW, NORM or HIGH. Press the Enter button to store the setting.

Setting the master-slave link mode

It is possible to control several machines from one digital remote. The machine with the remote plugged into it is set as the Master. The other machines are set as Slaves. The machines are interconnected with DMX cabling.

Use the Previous / Next buttons to select the LINK MODE option from the SETTINGS menu.

Use the Up/Down buttons to select RECEIVE (slave unit) or SEND (master unit). Press the Enter button to store the link setting.

The machine should be set to SEND only if it is running as a master. If running as a slave, stand-alone or DMX controlled it should be set to RECEIVE. If a machine set to SEND is connected to an active DMX system, the DMX will be corrupted causing flickering of lights and other strange symptoms.

Priming the machine after fluid out

If the machine runs out of fluid, it will automatically shut down and show FLUID OUT on the display to prevent damage to the pump(s). To suck the new fluid back into the machine and reset the FLUID OUT error, replace/refill the fluid tank and use the prime function.

Use the Previous / Next buttons to select the PRIME option from the SETTINGS menu. Use the Up/Down buttons to change the option to YES. Press the Enter button to start the priming function.

The pump(s) will operate at full power for a short time to purge air from the pipes inside the unit. To exit this menu if you decide not to activate the Prime function, select NO and press Enter.

Resetting options to factory settings

The factory settings configure a standard mode of operation for the machine.

Use the Previous / Next buttons to select the RESET option from the SETTINGS menu. Use the Up/Down buttons to change the option to YES. Press the Enter button to reset all options.

To exit this menu if you decide not to reset the options, select NO and press Enter.

The factory settings are:

option	setting
FOG LEVEL	50%
TIMER ON	10 seconds
TIMER OFF	20 seconds
RUN MODE	STANDBY
DMX	001
BACK LIGHT	NORM
LINK MODE	RECEIVE
PRIME	NO
TEMPERATURE*	NORM

*ZV ZR45 Only

DMX Control

Overview

DMX is a digital control system widely used in entertainment and architectural lighting. Any controller meeting the DMX-512 standard may be used to control and program the fog output of the ZV ZR45 SmokeMaker™ machine.



When a DMX signal is present, the ZV ZR45 SmokeMaker™ machine's stand-alone functions do not work. To fire the unit from the control panel or remote control, the DMX controller must be powered off or disconnected.

If the DMX signal is removed (controller turned off or unplugged), the machine will revert to its previously stored RUN MODE settings.

If the machine was set to OFF, it will revert to this state.
If the machine was set to STANDBY, it will revert to this state. If the machine was set to TIMER, it will revert to this state.
If the machine was set to CONTINUOUS, it will revert to this state.

Connection

The ZV ZR45 SmokeMaker™ machine provides 5-pin XLR connectors on the rear of the machine for DMX connection.

For best results, use cable designed for high speed digital data transmission.

DMX functions

The ZV ZR45 SmokeMaker™ address setting must match the DMX address allocated to it on your controller. To set the address, see "Setting the DMX base address" on page 16. The ZV ZR45 SmokeMaker™ machine requires one DMX channel.

When the machine is at running temperature and is under DMX control it displays DMX (+ the current DMX base address).

The DMX control values are shown in the table below.

Channel 1	DMX value range	Function	Macro description	Default value
Fog output level	0-12	Idle range	None	0
	13- 240	Output 0-100%		
	241 -255	Output 100%		

Optional PLC Interface Control

Overview

An Optional PLC interface is available that will replace the DMX functionality of the machine and provide analog control of fog output (on and off) and fog flow rate (0-100%) or can trigger a preset flow rate. This interface uses closed-contact signaling or can respond with 0-10V reference. Up to 5 machines can be daisy chained and controlled in this manner (subject to the drive capability of the controlling system). Physical connection is via 3-pin and 4-pin male locking XLR. Please contact American Safety & SmokeMaker for more detailed information on application and ordering.

Approved Fog Fluid Types

The ZV ZR45 SmokeMaker™ machine must only be used with the American Safety & SmokeMaker/JEM fluids listed below. American Safety & SmokeMaker supplies high quality fog fluids that are based on ultra-pure deionized water. No other fluid is suitable for use.

Pro Smoke Studio Fluid (DX mix)

In a studio or theatre environment, a lighter, faster dispersing fog is often preferred. Pro-Smoke Studio offers a less dense environment to Pro-Smoke Super and is therefore less likely to interfere with TV camera focusing.

Pro Smoke Super (ZR mix)

Pro Smoke Super fluid is a high-quality, general purpose fluid that produces a dense white airborne fog with medium dispersal time. Its medium to high index of refraction permits both good atmospheric effects and denser “white-outs”.

Pro Smoke High Density (SP mix)

Pro Smoke High Density fluid generates a high density, white, airborne fog with a very high index of refraction and slow evaporation rate. It is well suited for scenic obscuring, dramatic strobe effects, and “white-outs”.

I-fog fluid

i fog is not only kind to your lights, but is also more economical to use thanks to its incredible long “hang time” characteristics. It is well suited for scenic obscuring, dramatic strobe effects, and “white-outs”.

ZeroVisibility MAX

ZeroVisibility MAX Smoke Fluid is a clear, colorless, odorless, water-based Glycol fluid for Fire & Rescue Training, Military, Emergency Air Evacuation, Air Flow Studies, Leak Detection and other uses where intense, enduring, people-friendly smoke is required.

Pro Steam Simulation

ZR45

For ZV ZR45 SmokeMaker only - Pro Steam Simulation fluid is a light fluid that produces well-defined cones of vapor that disperse quickly. It is ideal for chase effects and theatrical use.



DANGER! The ZV ZR45 SmokeMaker™ machine can run safely only on the specific fog fluids they are designed for. Use **ONLY** the American Safety & SmokeMaker fog fluids designated in this manual. **NEVER** use any other type of fluid, or toxic gas may be produced. You will probably also cause damage to the machine that will invalidate the product warranty. Do not dilute fog fluid with water or any other liquid. Discard fog fluid if it becomes contaminated.

For more information visit us at:

<http://www.americansafetyandsmoke.com/>

ZR45 Temperature Menu

The different fluid types listed require correct selection of the relevant temperature setting in the TEMPERATURE sub-menu of the SETTINGS menu. Select the required temperature and press Enter to store.

The selected temperature setting will remain after power off and is indicated on the display whilst in standby (TEMP=NORM) and also shows during manual operation/DMX control (T=N).

TEMPERATURE Setting	Fluid Type
HIGH	Pro Smoke High Density (SP mix) i-fog
NORM	Pro Smoke Super (ZR mix) RUSH Fog Fluid Pro Smoke Studio (DX mix)
LOW	Pro Steam Simulation

Pro Clean Supreme Fluid

Specially designed for optimum performance while providing longevity of the heat exchanger, Pro Clean Supreme is the ultimate cleaning solution for American Safety & SmokeMaker fog and haze effect machines. Applying Pro Clean Supreme fluid on a regular basis reduces clogging and further extends the life of American Safety & SmokeMaker fog and haze machines.

Using Pro Clean Supreme every 200 hours, or once a month (depending on usage), will prolong the life of the heat exchanger in American Safety & SmokeMaker fog and haze machines. Connect Pro Clean Supreme fluid to the fogger or hazer, then allow the unit to heat. When fully ready, activate the machine or remote for approximately 30-45 minutes (use the timer function if available). When completed, replace cleaning fluid with appropriate fluid.

Note: Cleaning procedure should be used if the unit is to be stored for 30 days or more. Ensure there is no fluid in the fluid tube when placing in storage.

Basic Service



Before servicing the ZV ZR45 SmokeMaker machines, read and observe all the precautions listed in “Safety information” on page 4. Any service not described in this section must be carried out by a American Safety & SmokeMaker™ service technician.

<http://www.americansafetyandsmoke.com/contact-us.html>

Cleaning

Excessive dust, fog fluid, and dirt build-up will degrade performance and cause overheating and damage to the machine that is not covered by the product warranty. To maintain adequate cooling, dust must be cleaned from the outer casing and air vents of the machine periodically.



Isolate the machine from power and allow to cool completely before cleaning. The fog output nozzles remain hot for a period after use.

- Remove dust from the air vents with a soft brush, cotton swab, vacuum, or compressed air.
- Clean fog fluid residues from the fog output of the machine using a damp cloth.
- Clean the outer casing with a damp cloth only.

Fuse replacement

The main fuse for the machine is located adjacent to the power inlet on the rear panel. There is also a T3.15 A fuse located on the electronics board inside the unit which protects the supply to the pump.



DANGER! Disconnect the power supply before removing any covers or changing fuses. Live parts inside!

Rear panel fuse:

ZV ZR45

EU model = 12.5 AT (slow-blow), 250V

US model = 20 AT (slow-blow), 125V

Replace fuse only with one of exactly the same size and rating. Contact American Safety & SmokeMaker Service if the fuse blows repeatedly.

To replace the internal fuse, disconnect the power cord from the supply, unscrew the screws holding the top cover of the unit and remove the cover. The electronics board is located in the side compartment.

Troubleshooting

Problem	Probable cause(s)	Suggested remedy
Machine will not produce fog when control panel set to CONTINUOUS or fog button pressed	Machine not at operating temperature	Wait until HEAT message no longer shown
	FOG option set to 0	Increase setting
	Machine in timer mode and TIMER ON set to 0	Increase setting
	DMX signal present	Disconnect or turn off DMX controller
Machine can be fired from control panel, but not by DMX controller	DMX address setting incorrect	Change DMX address (page 16)
	Poor connection in DMX line	Check DMX cables and connections
	LINK menu is set to SEND	Set LINK menu to RECEIVE
Fog output is weak	Machine requires priming	Use PRIME option to prime the machine (page 14)
Wet, greasy, non-uniform fog output, fluid drips or spits from nozzle, or very loud noise when firing machine	Incompatible fog fluid	Use approved fluid!
Machine appears dead	Mains fuse blown	Replace fuse (page 21)
	No power at AC cable inlet	Check power cable and circuit breaker
Machine causes DMX errors to occur on other units when connected to a DMX system	LINK menu is set to SEND	Set LINK menu to RECEIVE
Loss of control from remote	Communication issue between remote and machine	Check cable connection between remote and machine

Status Messages

message	reason
OFF	The heaters are Off, the unit is shut down.
HEAT	The unit is heating up to operating temperature.
READY	The heater is at operating temperature, but Fog is not turned on (RUN set to STANDBY).
DMX	The heater is at operating temperature and the unit is under DMX control.
FLUID OUT	Run out of fluid. Refill the fluid tank and operate the prime function in the SETTINGS menu
CALIBRATION ERROR	The machine has detected an error with its calibration settings and will not operate. Call American Safety & SmokeMaker Support 1-888-289-2747
SYSTEM ERROR	The machine has detected an error in the temperature sensor and will not operate. Call American Safety & SmokeMaker Support 1-888-289-2747

Resetting the machine after fluid out

If the machine runs out of fluid, simply refill the fluid container and follow the priming instructions on page 14.

Technical Specifications

Physical

ZV ZR45

Length	602 mm (23.1 in.)
Width	395 mm (15.6 in.)
Height.....	306 mm (12.1 in.)
Height with hanging bracket	393 mm (15.5 in.)
Weight, dry	17.7 kg (39.1 lb.)
Weight, filled.....	22.7 kg (50.0 lb.)

Performance

ZV ZR45

Coverage volume	1300 m ³ (45,909 ft ³) per minute
Fluid consumption (max.)	80 ml per 30 seconds
Continuous effect output.	
Ready time.....	10 minutes

Control and programming

Control options	Integrated digital remote control, DMX optional PLC interface, master/slave link mode
Control parameters	Continuous or timer-controlled output
Fog	Variable output control, 0-100%

DMX channels	1
DMX compliance	ANSI E1.11 - USITT DMX512-A
RDM compliance	ANSI/ESTA E1.20
RDM	

Construction

Housing	Steel & aluminium
Hanging bracket	Integrated yoke with safety attachment point
Color	
Black	
Heat exchanger, ZV ZR45 EU	2000 W, thermally protected
Heat exchanger, ZV ZR45 US	1800 W, thermally protected
Fluid pump, AV ZR45	Dual oscillating piston, high pressure
Fluid management	Fluid out sensing, sealed for transportation
Fluid reservoir, AV ZR45	5 l drop-in reservoir with quick-connect fitting
External fluid control	Fluid sensing
Remote control	Integrated digital remote with 3 m cable, 3-pin XLR

Installation

Mounting	Standing or hanging
Clearance around machine	100 mm (4 in.)
Orientation	Up to +/- 40° from horizontal

Connections

AC Power	Neutrik PowerCON TRUE1
DMX, Link mode in/out	5-pin locking XLR
Remote control	3-pin locking XLR
Firmware	AVR socket
Optional PLC interface	3- and 4-pin locking XLR

Electrical I

All models

AC power (EU models)	220-240 V nominal, 50/60 Hz
AC power (US models)	100-130 V nominal, 50/60 Hz

AV ZR45

Main fuse (220-240V power)	12.5AT (slow-blow), 250 V
Main fuse (115-125V power)	20AT (slow-blow), 125 V

Typical Power and Current

ZV ZR45 (EU model)	2100 W, 9.2 A*
ZV ZR45 (US model)	1800 W, 15 A*

*Measurements made at nominal voltage. Allow for a deviation of +/-10%

Thermal

Maximum ambient temperature (Ta max).....	40°C (104°F)
Exterior surface temperature, steady state, at 20°C ambient	30°C (86°F)
Max nozzle temperature.....	290°C (554°F)
Minimum ambient temperature (Ta min)	5°C (41°F)

Approvals

EU Model

EU safety:	EN 60 335-1+A15, EN62233
EU EMC:	EN61000-6-3
EU Immunity:	EN 61000-6-1
Australia/NZ (pending)	RCM

US Model

US safety	UL998
Canada safety	CSA C22.2 No.104.01



Included items:

User manual	P/N 35010042
Fluid reservoir ZV ZR45, 5 l	P/N 34300506
ZV ZR/JEM series™ Digital Remote Control.....	P/N 55765048
ZV ZR45 EU, power input cable, PowerCON TRUE1, stripped ends, 3 m (9.ft.)	P/N 11501043
ZV ZR45 US, power input cable, 20A, PowerCON TRUE1, molded NEMA 5-20P, 2 m (6.6 ft.)	P/N 11501046

Accessories

ZV ZR series™ PLC Interface	P/N 92765049
ZV ZR45™ Ducting System, with 5 m (16.4 ft.) ducting	P/N 92625014

Approved Fluids

Pro Smoke Studio
Pro Smoke Super
Pro Smoke High Density
ZeroVisibility MAX
i-FogFluid
Pro Steam Simulation (ZV ZR45 only)
Pro Clean Supreme

**Various sizes available – contact American Safety & SmokeMaker for details.*

Installation Hardware

Half-coupler clamp.....	P/N 91602005
G-clamp (vertical hanging suspension only)	P/N 91602003
Quick trigger clamp (vertical hanging suspension only)	P/N 91602007

Service Tools

Epsilon 5 AVR Programmer	P/N 50502004
Temperature Calibration Box	P/N 92620005

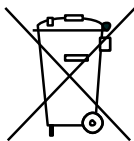

Disposing of this product

American Safety & SmokeMaker products are supplied in compliance with Directive 2002/96/EC of the European Parliament and of the Council of the European Union on WEEE (Waste Electrical and Electronic Equipment), as amended by Directive 2003/108/EC, where applicable.

Help preserve the environment! Ensure that this product is recycled at the end of its life.





513 Stewart Street, Suite G, Charlottesville Virginia 22902
www.AmericanSafetyandSmokeMaker.com • American Safety & Health Promotions LTD
Email: Solutions@AmericanSafetyandSmokeMaker.com
Call Toll Free: 888-289-2747 • Local: 434-977-2700 • fax: 434-977-0111